

PROTOCASE

Custom Electronic Enclosures
For Engineers & Designers

TECHNICAL BULLETIN

How to Design Custom Enclosures for Motherboard-Based Systems

(covering ATX and Mini ITX form factors)

Document Edition - 1
Last Updated: June 6th, 2011
Protocase, Inc. All Rights Reserved.

WWW.PROTOCASE.COM

North America

Toll Free: 1-866-849-3911

Tel: 1-902-567-3335

Fax: 1-902-567-3336

United Kingdom

Telephone: 0203 0049981

info@protocase.co.uk

info@protocase.com



How to Design Enclosures for Motherboard-based Systems

INTRODUCTION

Today, engineers who design custom electronic devices often integrate standard-form factor motherboards into their systems in order to take advantage of the powerful computing capacity and reliability that these boards offer at a very reasonable price point. The common ATX motherboard is ubiquitous, powerful, and cost effective. Mini-ITX motherboards have been developed specifically for applications where small size, low power consumption, and minimum noise are paramount. This paper covers the key elements of designing custom metal enclosures, that are capable of accommodating ATX and Mini-ITX motherboards, and provides important details such as dimensions, mounting the boards, and how to access to I/O connectors. In addition, many of the concepts in this paper also apply to the design of enclosures for other motherboard form factors and custom built circuit boards.

CONCEPTS

In this document, we will assume that the board is being mounted horizontally, on the base of the enclosure, and that the I/O connectors are accessed through the rear of the enclosure. This is assumed for consistency of presentation, and of course, the enclosure may actually be designed with the board in any orientation.

- Certain specific dimensions, such as mounting hole patterns and I/O connector block locations, have been standardized on all ATX and mini-ITX motherboards.
- Designing the mounting pattern on the base, and I/O and/or card slot openings on the rear are key tasks.
- Minimum clearances between the edges of the motherboard, fans, components, drives, cables, etc., and the sides of the enclosure must be considered when designing enclosures.
- Motherboards must be attached to the enclosure with standoff fasteners (to avoid direct contact between board circuitry and the enclosure surface).
- Adequate ventilation must be designed into the enclosure to avoid component overheating.
- Location of mounting holes, and cutouts for I/O / PCI Cards, are given relative to an origin on the corner of the motherboard. These must be offset correctly when transferred to your enclosure design. Key factors such as desired offset of board from inside surfaces, thickness of enclosure walls, and height of standoffs, must be considered.

OTHER RESOURCES

Downloadable CAD Drawings All of the drawings shown in this document, as well as other details related to enclosures for motherboards, are contained in CAD files that may be downloaded free of charge on the “Resources” page of the Protocase website, <http://www.protocase.com/resources/>. They are available in Solidworks .sldprt, 2D .dxf, and .pdf formats. The .sldprt file also contains details for other boards in addition to mini-ITX and ATX.

Further information The website <http://www.formfactors.org/> is a definitive source of information on motherboards.

Advanced Design Tools and Manufacturing Anyone who designs custom electronic enclosures should be aware of the following resources:

- Protocase's online template generator will automatically create basic enclosure designs (rackmount, L, U, consolet) for you in a CAD format of your choice, thereby saving you the effort of designing from scratch. http://www.protocase.com/v3/design/template_generator.php.
- Protocase Designer(r) free downloadable 3D CAD software for enclosure design, utilizes a time-saving template based approach, and also offers instant online quotes and online ordering. <http://www.protocasedesigner.com/>.
- See Protocase's website <http://www.protocase.com/> for custom enclosure manufacturing with 2-3 day turnaround and no minimum order requirements.

WHERE AND HOW TO MOUNT THE BOARD

The I/O edge is typically placed 0.065 from the enclosure wall, to correctly accommodate the I/O plate adaptor and the PCI card brackets. Allow a **minimum 0.250”(6.35mm) clearance** from the other board edges to their corresponding side panels. It is possible to use smaller clearances for these sides, but it then becomes necessary to very carefully consider possible interferences between the board and enclosure details such as flanges, fasteners, and bend radii. If using smaller clearances, be sure to discuss this with Protocase technical staff.

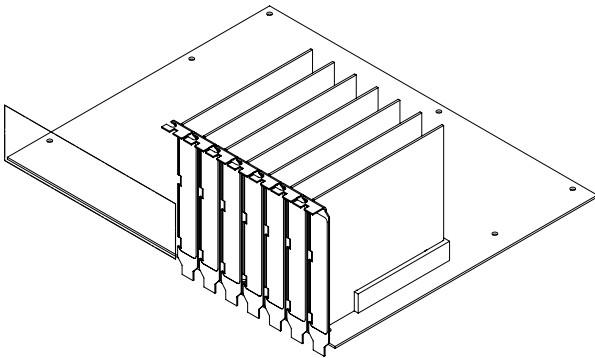

Figure 1 – ATX Board with PCI Cards

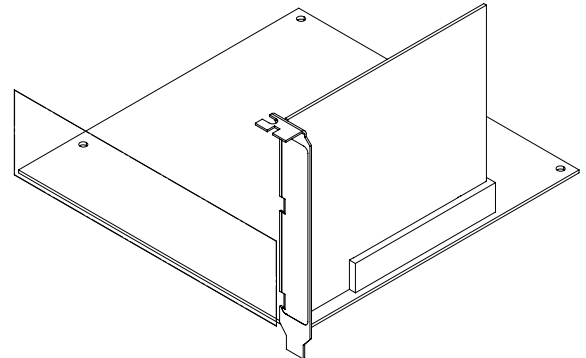

Figure 2 – Mini-ITX Board with PCI Card

Use standoffs to raise the board above the floor of the enclosure to avoid contact of parts on the underside with the metal casing (see Figure 3 below). Standard motherboard mounting holes accept a 6-32 thread size. PEM style self clinching standoffs are usually the most convenient way to achieve this. A **3/8” (9.53mm) standoff** should be suitable for most boards.

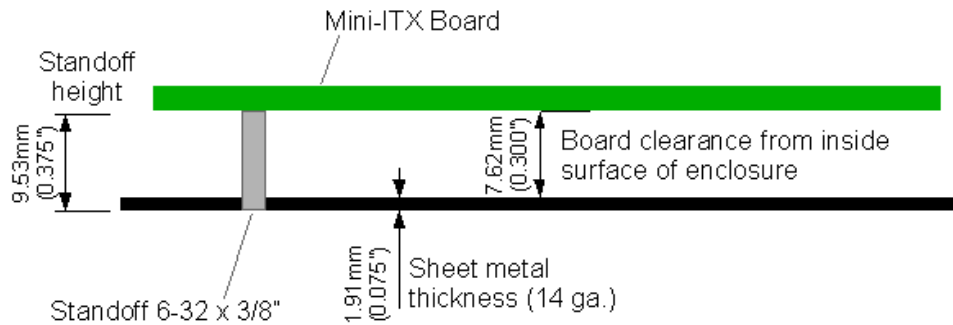

Figure 3 – Minimum offsets from bottom panel of an enclosure.

Allow a minimum of 0.250” (6.35mm) clearance from the top of the highest component to the inside of the top of the enclosure. If you intend to use a fan-cooled processor in a situation with little clearance between the fan and the enclosure wall, we recommend fans that pull air directionally across the processor heat sink rather than down onto the top of the sink.

Keep in mind that PEM standoffs extend through the sheet metal from the outside face of the enclosure panel, so the thickness of the metal must be taken into account when considering the standoff distance between board and enclosure. A 0.375” (9.53mm) standoff, mounted in a 14 gauge (0.075”) enclosure wall, will provide only 0.300” (7.62mm) clearance to the to the surface of the board, and less if the metal is thicker.

VENT CUTOUT PLACEMENT

Consider the orientation of fans, and align intake and exhaust outlets to take advantage of the current that they create. It is best to arrange the intake and exhaust cutouts so that air will flow across the top of the board on its way through your enclosure. See Figure 4 for some examples of ventilation cutout placements. To maximize the effect of ventilation airflow, make sure that the only openings in your enclosure are the ventilation cutouts or openings that will be filled by switches, connectors, or panel display features. Extraneous holes in the enclosure panels can cause disruption of natural convection currents, resulting in less effective cooling of the processors. And if in doubt, use a fan or fans to move air in and out of your enclosure. The required volume of cooling air can be calculated as $\text{Volume (CFM)} = 3.16 \times \text{Max Heat (watts)} / \Delta T (\text{F})$, where Max Heat is the maximum sustained power dissipation of boards and components inside the enclosure, and ΔT is the maximum allowable temperature rise.

Designs with air intake cutouts in the bottom panel should include feet to raise the enclosure off of its support surface. Avoid placing cutouts directly beneath the motherboard which may allow objects to accidentally poke up through the spaces and contact the board, causing unwanted damage. It is better to place bottom panel cutouts outside the perimeter of the motherboard.

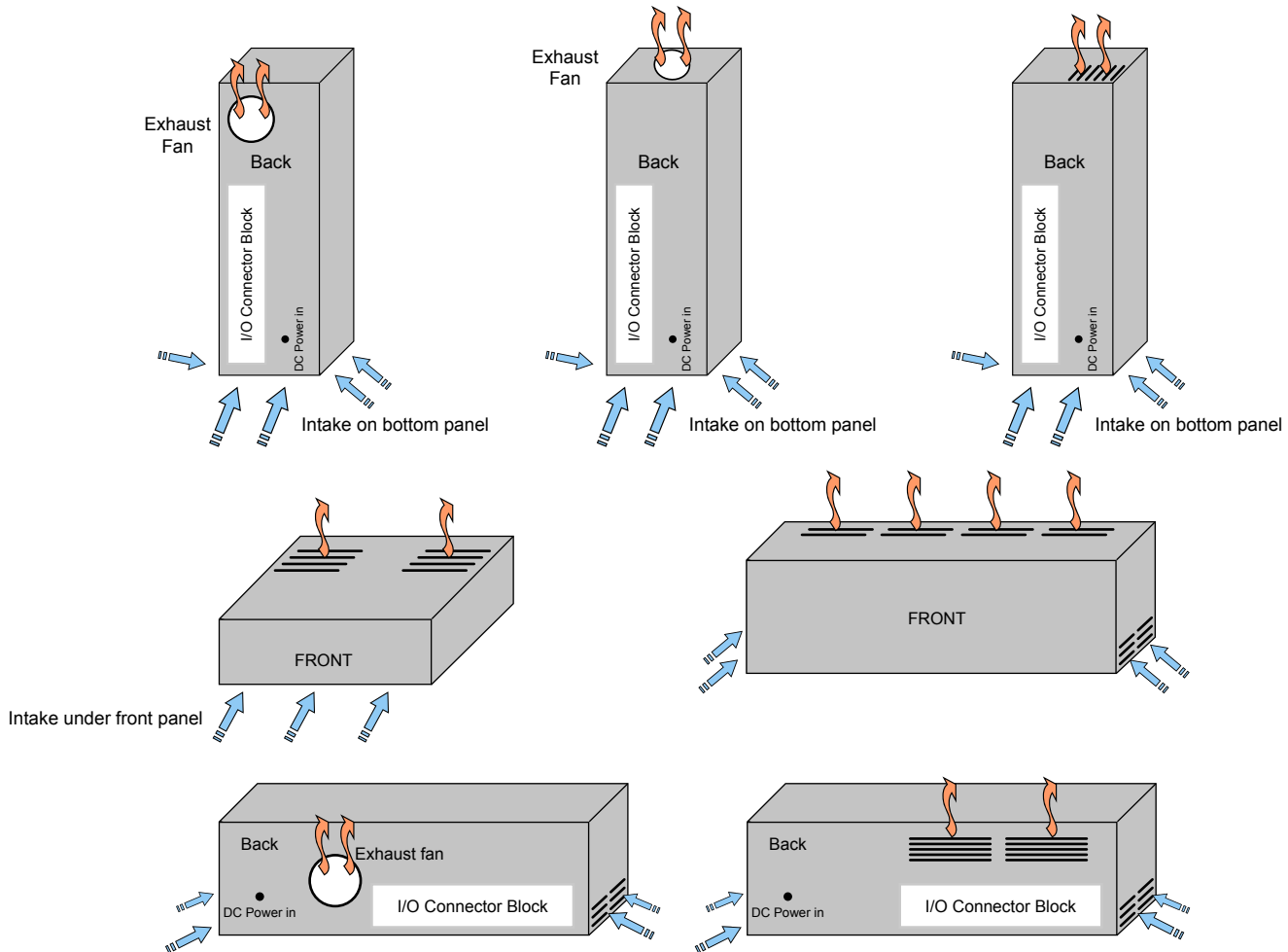

Figure 4 – Suggested placement of ventilation cutouts and enclosure exhaust fans. (Example uses ITX enclosure)

DESIGNING THE BASE

ATX and Mini ITX motherboards are available in a wide range of configurations, but they utilize standard overall dimensions, mounting points, PCI card details, and Input/Output (I/O) connector block areas.

Mounting holes, standoffs, and offsets Figures 5 and 6 show the mounting hole patterns, with dimensions referenced from the lower right corner of the motherboard. To locate the board correctly within your enclosure, offsets must be added to these coordinates so that there is sufficient clearance between the edges of the board and the enclosure walls. The I/O is accessed from what is shown as the lower edge of the board, as oriented in these drawings. This edge should be offset 0.065" (1.65mm) from the inner face of the enclosure wall. This allows the I/O plate (this is a small metal panel that comes with the motherboard, and mounts over the I/O connectors) to be mounted, and for the metal brackets on the PCI cards. The remaining sides of the motherboard should be offset a minimum of 1/4" from the inner face of enclosure walls. In order to mount the motherboard at the correct height, it is recommended that 6-32 x 3/8" standoffs be specified. Self-clinching ('PEM') type fasteners are usually preferred. If you do not use 6-32 x 3/8" self-clinching standoffs, take care to consider issues surrounding PCI card tab slots, and the height of cutouts for the I/O block and PCI card cutouts.

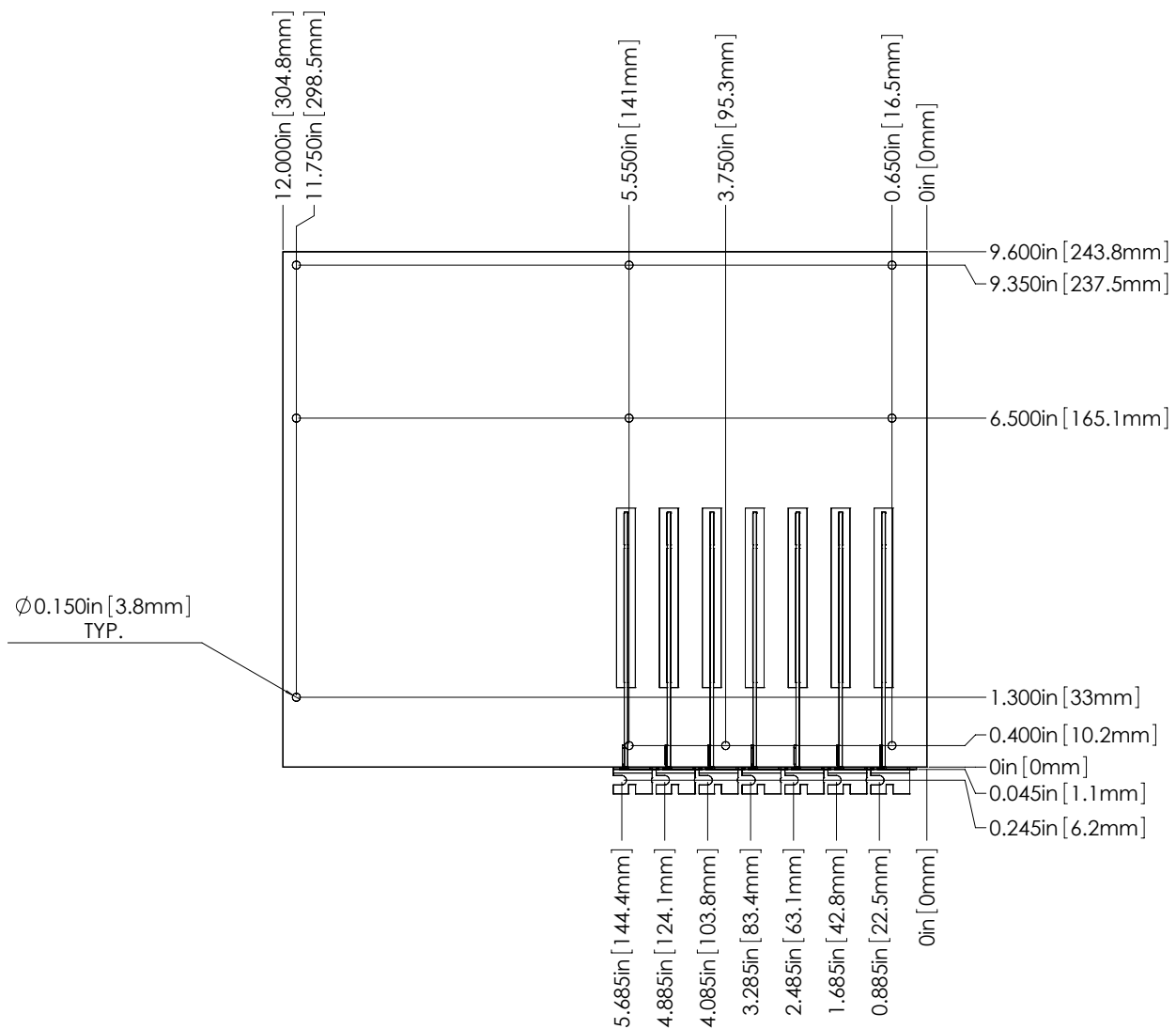

Figure 5 – ATX board top view, with overall dimensions and mounting points

PCI Card Tabs A final detail that must be considered when designing the base, is the accommodation of tabs that are found on the bottom of PCI Card Brackets. These tabs are designed to fit into a slot in the base of the enclosure, in order to help secure the card. Figures 7 and 8 show the size and position of these slots. This slot design applies if using the recommended 3/8" high standoffs, and this requirement can be avoided by using 7/16" or longer standoffs. Caution should be used if using shorter standoffs, as larger clearances will be required and the end of the brackets may protrude below the base of the enclosure.

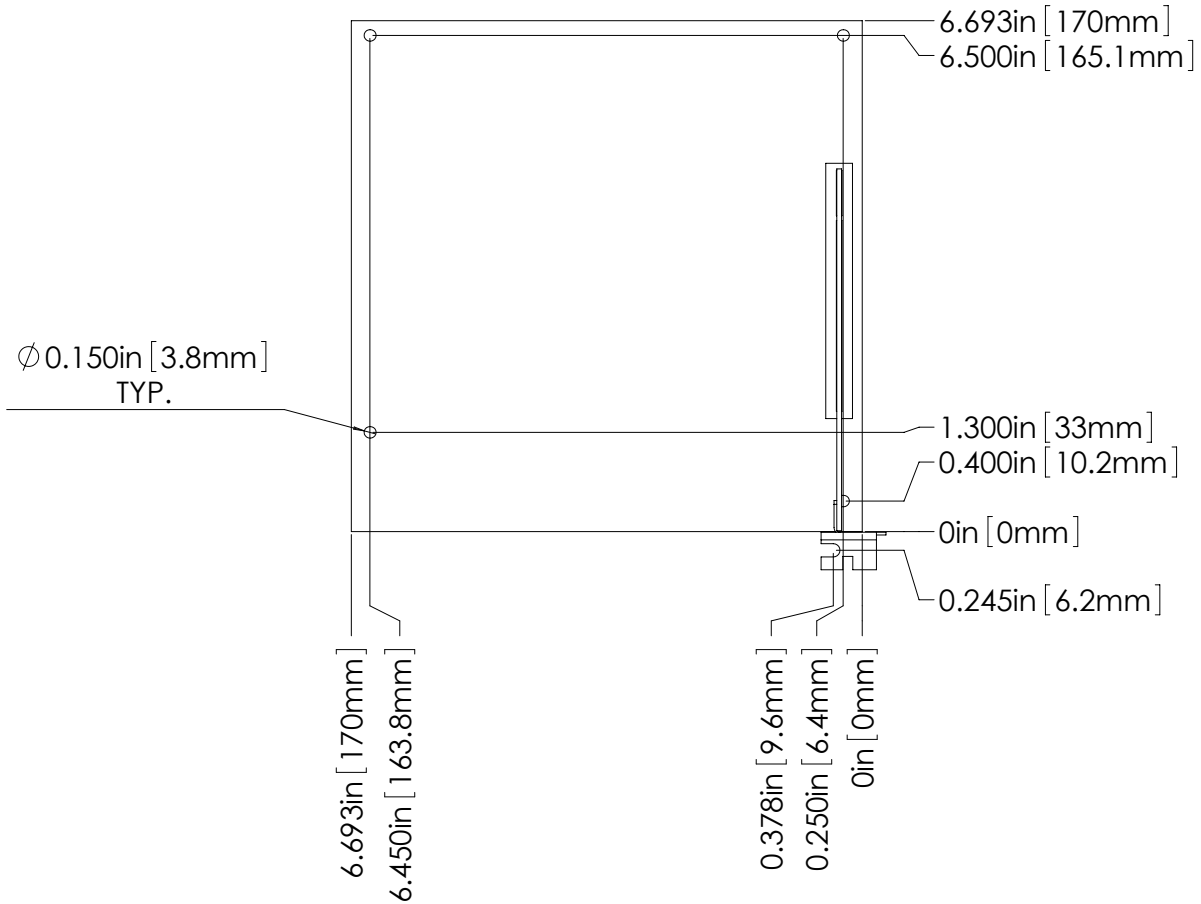

Figure 6 – mini-ITX board top view, with overall dimensions and mounting points

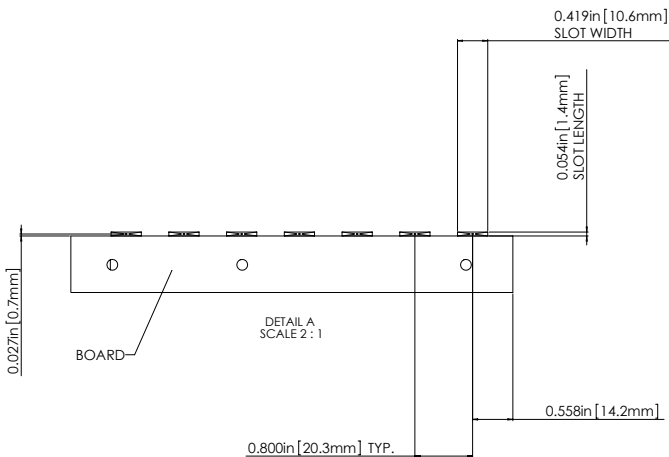

Figure 7 – ATX enclosure base, PCI Card slot detail for 3/8"

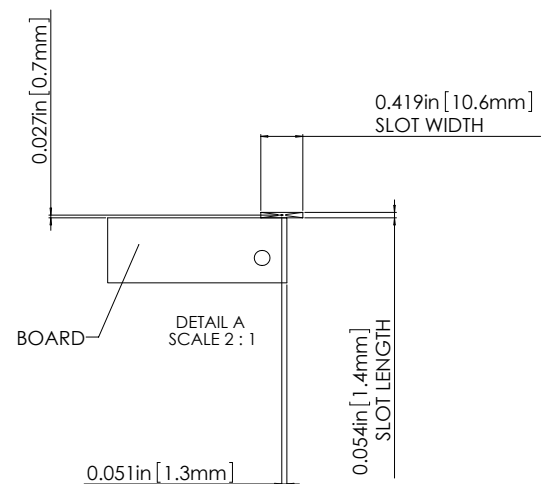

Figure 8 – mini-ITX enclosure base, PCI Card slot detail for 3/8" standoffs

DESIGNING THE BACK PANEL WITH I/O CONNECTOR BLOCK AND PCI CUTOUTS

ATX and mini ITX boards have a standard size I/O connector block and PCI area. The standard cutout for PCI slot access is shown in Figures 9 and 10. These drawings assume use of 6-32 x 3/8" self-clinching standoffs which position the bottom of the board 0.375" (9.53mm) from the outside of the base. Should you use standoffs of different length, you must adjust the vertical position of these cutouts accordingly. Also, horizontal dimensions are from the corner of the motherboard, so be sure to horizontally offset the pattern by an appropriate amount, to match the offset you chose when designing the base.

I/O Area A simple rectangular cutout is all that is required to accommodate the I/O connectors. A metal I/O plate is supplied with most motherboards, that will snap into this opening while fitting around the I/O connectors.

PCI Slots The standard slot-style cutouts for PCI card access are shown in Figures 9 and 10. Adjust vertical and horizontal offsets as per I/O area cutouts. If you are not anticipating using all the slots, you can either omit cutouts as required, or specify 'knockouts' which refers to cutting almost all the way around the perimeters of the cutouts, but leaving several very small metal 'bridges' that keep the center in place until the user decides to physically remove it. Use caution with knockouts if using cold rolled steel in damp or corrosive environments, as small bare metal patches will be left once the centers are removed. And finally, a last detail that should be considered is that, if PCI cards will be used, a flange should be designed on the top edge of the back panel to allow PCI card brackets to be fastened. Screw holes should be placed at the dimensions shown for the screw opening on the top of the PCI card brackets, as shown in Figures 3 and 4. The holes should be drawn as diameter 0.1065" (2.71mm), and noted as "tap with 6-32 thread". There is typically insufficient space to use a self-clinching PEM nut here. You may also wish to add cosmetic details to the cover to hide this flange.

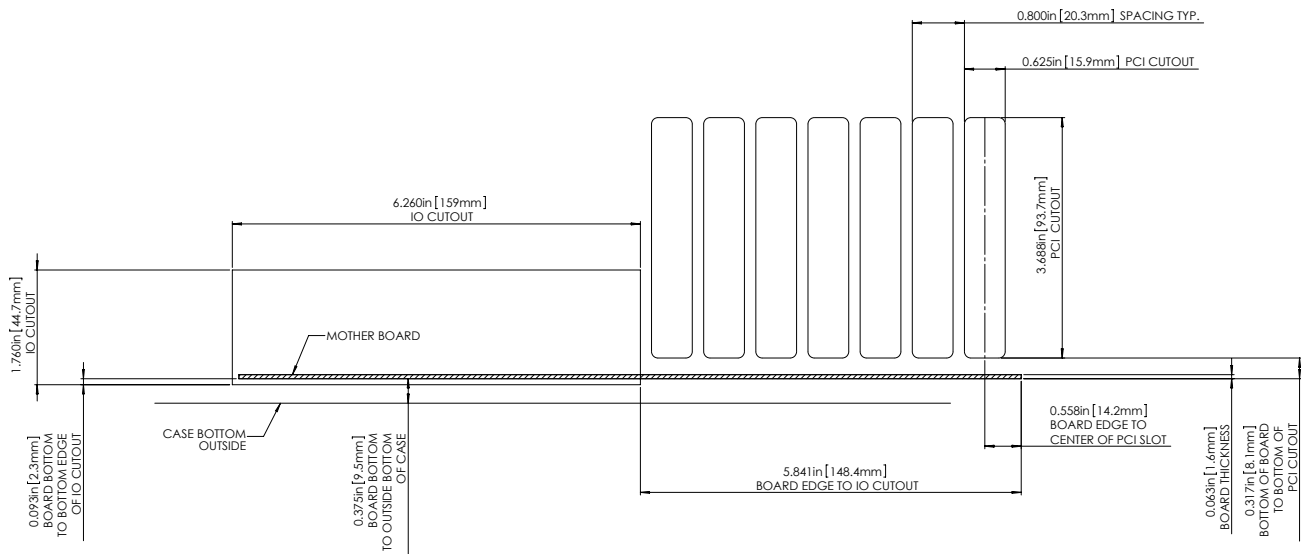

Figure 9 – ATX enclosure back panel I/O and PCI cutouts

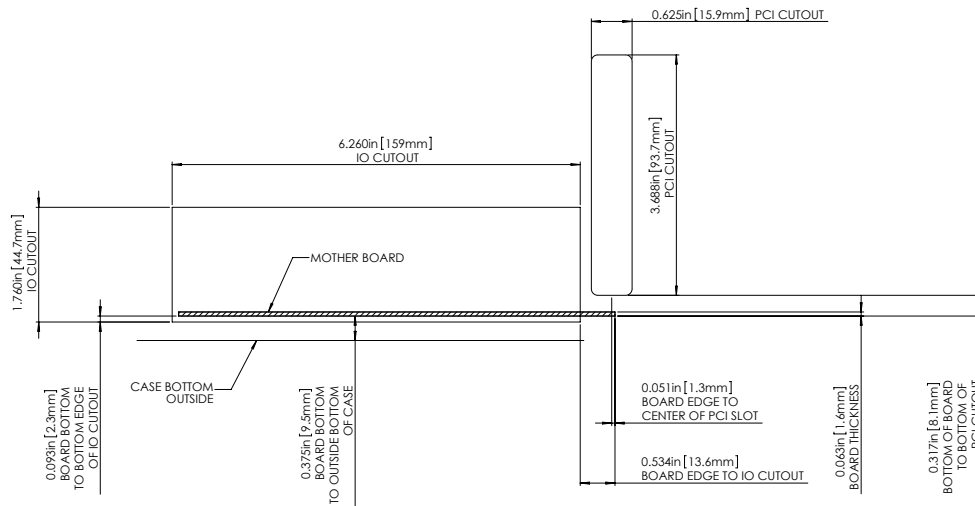

Figure 10 – mini-ITX enclosure base, PCI Card slot detail for 3/8" standoffs

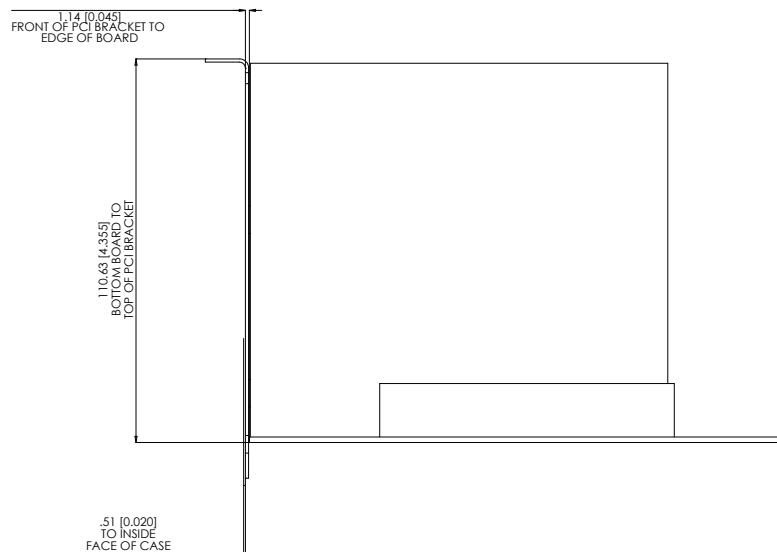

Figure 11 – right hand view of motherboard and PCI card

USING PROTOCASE DESIGNER® 3D CAD FOR ENCLOSURE DESIGN

Protocase Designer is 3D CAD software that enables users to quickly design customized electronic enclosures and to get instant quotes and buy online. Protocase Designer can be learned very quickly, and is available free of charge at <http://www.protocasedesigner.com/>.

If using Protocase Designer, be aware that it uses the lower left corner of the front face of the enclosure as the origin. The front face of the front panel of the enclosure will be at depth 0. The outside face of the rear of the enclosure, where you will most likely be placing the I/O connector block, will be at the maximum depth dimension of your enclosure. Since the connectors must project from the rear panel, calculate the standoff positions from the rear of the enclosure, allowing for the thickness of the metal.

Limitations and Work Arounds As of the date of this document, Protocase Designer will not accept PCI card tab slots, as they fall on a bend radius. Also, the templates do not include the flange for fastening the top of PCI card brackets. These limitations will be addressed in future releases. At the present time, a design can be submitted without these details, and if Protocase technical staff are informed at time of order, they can simply add these details for you.